



# Oracle

## Exam 1z0-850

**Java Standard Edition 5 and 6, Certified Associate Exam**

Version: 6.0

**[ Total Questions: 242 ]**

## Topic 1, Volume A

### Question No : 1 - (Topic 1)

Which two are true? (Choose two.)

- A. J2EE runs on consumer and embedded devices.
- B. J2EE includes the MIDP API.
- C. J2EE includes servlet APIs and EJB APIs.
- D. J2EE application developers need J2SE.
- E. J2EE applications depend on web servers.

**Answer: C,D**

### Question No : 2 - (Topic 1)

Which two are associated with the web tier in a J2EE web-based application? (Choose two.)

- A. servlets
- B. JAX-RPC
- C. JMS
- D. entity beans
- E. JSP

**Answer: A,E**

### Question No : 3 - (Topic 1)

Given:

1. class Test {
2. public static void main(String args[]) {
3. int num1 = 10, num2 = 20, result;
4. result = calc(num1, num2);
5. System.out.println(result);

```
6. }  
7.  
8. // insert code here  
9. }
```

Which, inserted at line 8, produces the output 30?

- A. `static int calc(int n1, int n2) { return; }`
- B. `public int calc(int n1, int n2) { return n1 + n2; }`
- C. `public int calc(int n1, int n2) { return; }`
- D. `static int calc(int n1, int n2) { return n1 + n2; }`
- E. `static void calc(n1, n2) { return (n1 + n2); }`
- F. `static int calc(int n1, n2) { return n1, n2; }`

**Answer: D**

#### Question No : 4 - (Topic 1)

Given:

```
1. public abstract class Wow {  
2.     private int wow;  
3.     public Wow(int wow) {  
4.         this.wow = wow;  
5.     }  
6.     public void wow() { }  
7.     private void wowza() { }  
8. }
```

Which is true about the class Wow?

- A. It does NOT compile because an abstract class must have at least one abstract method.
- B. It does NOT compile because an abstract class CANNOT have instance variables.

- C. It compiles without error.
- D. It does NOT compile because an abstract class CANNOT have private methods.
- E. It does NOT compile because an abstract class must have a constructor with no arguments.

**Answer: C**

### Question No : 5 - (Topic 1)

Given:

1. class X {
2. private Y y;
3. public X(Y y) { this.y = y; }
4. }
5. class Y {
6. private X x;
7. public Y() { }
8. public Y(X x) { this.x = x; }
9. }

The instance variable y is intended to represent the composition relationship "X is composed of Y."

Which code correctly maintains this meaning?

- A. X x1 = new X(new Y());  
X x2 = new X(new Y());
- B. X xx = new X(null);  
Y y1 = new Y(xx);  
Y y2 = new Y(xx);
- C. Y yy = new Y();  
X x1 = new X(yy);  
X x2 = new X(yy);
- D. Y y1 = new Y(new X(null));

```
Y y2 = new Y(new X(null));
```

**Answer: A**

**Question No : 6 - (Topic 1)**

Which type of J2EE component is used to store business data persistently?

- A. stateless session beans
- B. JavaBeans
- C. stateful session beans
- D. entity beans
- E. JavaServer Pages

**Answer: D**

**Question No : 7 - (Topic 1)**

What is the purpose of JNDI?

- A. to access native code from a Java application
- B. to parse XML documents
- C. to access various directory services using a single interface
- D. to register Java Web Start applications with a web server

**Answer: C**

**Question No : 8 - (Topic 1)**

Which two are true about HTML? (Choose two.)

- A. HTML can set up hypertext links between documents.
- B. HTML uses tags to structure text into headings, paragraphs, and lists.
- C. HTML is an object-oriented programming language.
- D. HTML documents CANNOT be browsed by a text editor.

**Answer: A,B**

**Question No : 9 - (Topic 1)**

Given:

```
4. class Example {  
5. int x = 50;  
6. int y = 100;  
7. public static void main(String args[]) {  
8. int x = 0, y = 10;  
9. Example ex = new Example();  
10. while (x < 3) {  
11. x++; y--;  
12. }  
13. System.out.println("x = " + x + " , y = " + y);  
14. }  
15. }
```

What is the result?

- A. Compilation fails because of an error at line 8.
- B. x = 3 , y = 7
- C. Compilation fails because of an error at line 11.
- D. Compilation fails because of an error at line 9.
- E. x = 53 , y = 97
- F. Compilation fails because of an error at line 10.

**Answer: B**

**Question No : 10 - (Topic 1)**

You have developed a MIDlet that runs on a Java-enabled Personal Digital Assistant (PDA) device. Now, your employer has asked you to port the MIDlet to run on other Java platforms. Which is true?

- A. The MIDlet is 100% portable across all J2ME devices.
- B. The MIDlet can run within a standard web browser.
- C. The MIDlet is guaranteed to run correctly under J2SE.
- D. The MIDlet is NOT guaranteed to run on a Java technology-enabled phone.

**Answer: D**

**Question No : 11 - (Topic 1)**

Which statement is true?

- A. JMS enables an application to provide flexible, asynchronous data exchange.
- B. JMS provides interfaces to naming and directory services.
- C. The JMS API is located in the java.jms package.
- D. JMS enables an application to provide tightly coupled, distributed communication.

**Answer: A**

**Question No : 12 - (Topic 1)**

Which two are true about stateless session beans? (Choose two.)

- A. They are used to represent data stored in an RDBMS.
- B. They implement the JMS API.
- C. They are used to implement business logic.
- D. They CANNOT hold client state.

**Answer: C,D**

**Question No : 13 - (Topic 1)**

Which two are true about javax.swing? (Choose two.)

- A. It includes classes for creating buttons and panels.
- B. It is used to create MIDlets.
- C. It is used to create applications that have the same user interface on different platforms.
- D. It uses the native GUI components of each platform.

Answer: A,C

**Question No : 14 - (Topic 1)**

Which two are true? (Choose two.)

- A. An interface CANNOT be extended by another interface.
- B. An abstract class CANNOT be extended by an abstract class.
- C. An interface can be extended by an abstract class.
- D. An abstract class can implement an interface.
- E. An abstract class can be extended by a concrete class.
- F. An abstract class can be extended by an interface.

Answer: D,E

**Question No : 15 - (Topic 1)**

Click the Exhibit button.

Which relationships, referenced by the class names involved, are drawn using valid UML notation?

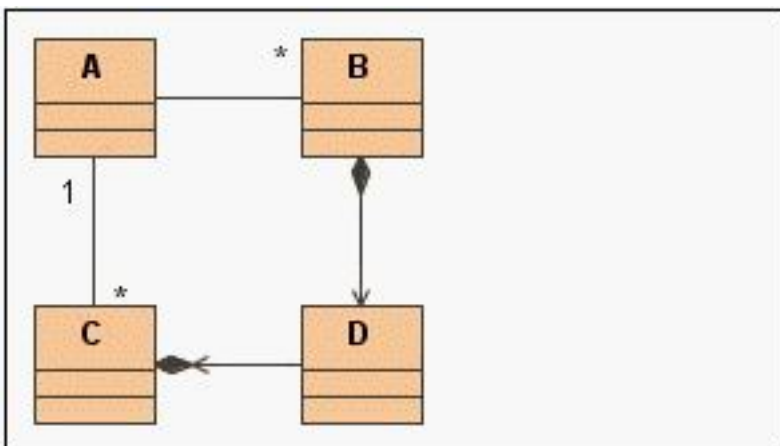

- A. AB, AC, BD, and CD



- B. only AC, BD, and CD
- C. only AB, AC, and BD
- D. only AB and AC
- E. only BD and CD

**Answer: A**

### Question No : 16 - (Topic 1)

Given:

- 12. String s = "abcdefgabc";
- 13. char c = s.charAt(2);
- 14.
- 15. if (c == 'c')
- 16. s = s.replace('c', 'X');
- 17. else if (c == 'b')
- 18. s = s.replace('b', 'O');
- 19. else
- 20. s = s.replace('c', 'O');
- 21. System.out.println(s);

What is the result?

- A. aOcdefgabc
- B. Compilation fails.
- C. abOdefgabc
- D. abXdefgabc
- E. abOdefgabO
- F. aOcdefgaOc
- G. abXdefgabX

**Answer: G**

**Question No : 17 - (Topic 1)**

Which package contains classes used to create data collections, such as maps or queues?

- A. java.lang
- B. java.io
- C. java.awt
- D. java.net
- E. javax.swing
- F. java.util

**Answer: F**

**Question No : 18 - (Topic 1)**

Given:

1. interface A { }
2. interface B { void b(); }
3. interface C { public void c(); }
4. abstract class D implements A,B,C { }
5. class E extends D {
6. void b() { }
7. public void c() { }
8. }

Which is true?

- A. Compilation fails due to an error in line 6.
- B. The code compiles without error.
- C. Compilation fails due to an error in line 2.
- D. Compilation fails due to an error in line 4.
- E. Compilation fails due to an error in line 1.

**Answer: A**

**Question No : 19 - (Topic 1)**

What type of relationship is needed to represent the relationship between students and the courses they are enrolled in at a university?

- A. a one-to-one composition
- B. a one-to-one association
- C. a many-to-many composition
- D. a one-to-many composition
- E. a one-to-many association
- F. a many-to-many association

**Answer: F**

**Question No : 20 - (Topic 1)**

Which two are features of JNDI? (Choose two.)

- A. an interface to store and retrieve named Java objects of any type
- B. an interface to search for objects using attributes
- C. a defined common set of messaging concepts and programming strategies
- D. connectivity to databases and other tabular data sources

**Answer: A,B**

**Question No : 21 - (Topic 1)**

You need to create a class that maintains a customer's account balance. The class must allow both credits (deposits) and debits (withdrawals) to the account.

Which class correctly implements this functionality?

- A. 

```
public class Account {  
    double balance;
```

```
public void debit(double amount) {  
    amount = balance - amount;  
}
```

```
public void credit(double amount) {  
    amount = balance + amount;  
}
```

```
B. public class Account {  
    double balance;  
    public void debit(double amount) {  
        balance = balance - amount;  
    }  
    public void credit(double amount) {  
        balance = balance + amount;  
    }  
}
```

```
C. public class Account {  
    double balance;  
    balance = balance - amount;  
}  
public void credit(double amount) {  
    double balance;  
    balance = balance + amount;  
}
```

```
D. public class Account {  
    public void debit(double amount) {  
        double balance;  
        balance = balance - amount;  
    }  
    public void credit(double amount) {  
        double balance;  
        balance = balance + amount;  
    }  
}
```

```
E. public class Account {  
    double balance;  
    public void debit() {  
        double debit;  
        balance = balance - debit;  
    }  
    public void credit() {  
        double credit;  
        balance = balance + credit;  
    }  
}
```

**Answer: B**

**Question No : 22 - (Topic 1)**

Which two are associated with the web tier in a multitier web-based application? (Choose two.)

- A. generate dynamic content
- B. implement business logic
- C. process user input
- D. integrate with database systems
- E. store state persistently

**Answer: A,C**

**Question No : 23 - (Topic 1)**

Click the Exhibit button.

Which correctly implements the relationships shown in the diagram?

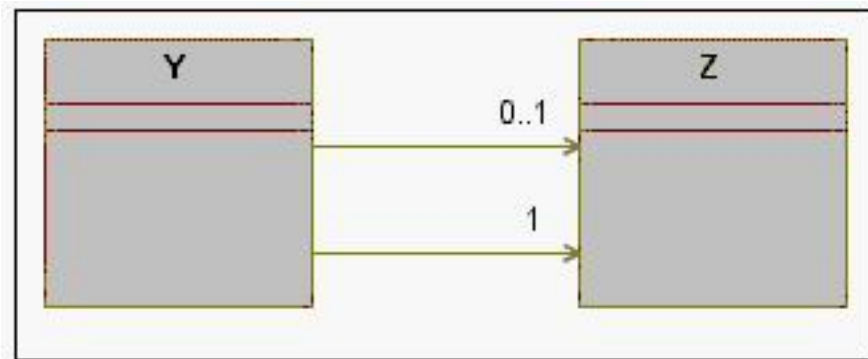

- A. 

```
public class Y {
private Z[] z1and2;
public Y(Z[] z1and2) {
if (z1and2 == null || z1and2.length != 2) {
System.exit(1); // ERROR!
}
this.z1and2 = z1and2;
}
}
```
- B. 

```
public class Z {
private Y[] y1and2;
public Z(Y[] y1and2) {
```

```
if (y1and2 == null || y1and2.length != 2) {  
    System.exit(1); // ERROR!  
}  
this.y1and2 = y1and2;  
}  
}
```

```
C. public class Z {  
    private Y y1;  
    private Y y2;  
    public Z(Y y1) {  
        if (y1 == null) System.exit(1); // ERROR!  
        this.y1 = y1;  
    }  
    public Z(Y y1, Y y2) {  
        this(y1);  
        this.y2 = y2;  
    }  
}
```

```
D. public class Y {  
    private Z z1;  
    private Z z2;  
    public Y(Z z1) {  
        if (z1 == null) System.exit(1); // ERROR!  
        this.z1 = z1;  
    }  
    public Y(Z z1, Z z2) {  
        this(z1);  
        this.z2 = z2;  
    }  
}
```

**Answer: D**

### **Question No : 24 - (Topic 1)**

Which is a benefit of Swing clients?

- A.** They can be used without a JRE on the client.
- B.** They are more universally supported by browsers than thin clients.
- C.** They can provide a richer graphical user interface experience than thin clients.
- D.** They are easier to deploy than thin clients.

**Answer: C**

**Question No : 25 - (Topic 1)**

Given:

```
1. class Test {  
2. public static void main(String args[]) {  
3. int num;  
4. num = 10;  
5. calc(num);  
6. System.out.println("num = " + num);  
7. }  
8.  
9. static void calc(int num) { 1  
0. num += 100; 11. } 12. }
```

What is the result?

- A. num = 10
- B. num = 100
- C. Compilation fails because of an error at line 3.
- D. num = 110
- E. Compilation fails because of an error at line 9.

**Answer: A**

**Question No : 26 - (Topic 1)**

Given:

```
1. abstract class A {}  
2. class B {}
```

3. interface C {}
4. interface D {}
5. // insert code here

Which, inserted at line 5, results in a compilation failure?

- A. class E implements C {}
- B. class E extends B implements D {}
- C. class E extends A {}
- D. interface E extends C, D {}
- E. class E extends A, B {}
- F. class E implements C, D {}

**Answer: E**

### **Question No : 27 - (Topic 1)**

Why should package names in Java be unique?

- A. to provide the Internet location from which the package can be downloaded
- B. to programatically declare specific ownership of classes in the package
- C. to avoid class name conflicts if two development groups use the same package and class names
- D. to allow classes in the package to be accessed by classes outside of that package

**Answer: C**

### **Question No : 28 - (Topic 1)**

Given:

18. String s = " abcdcba ";
19. int x = 2;
20. s = s.trim();
21. if (s.length() < 8) {



22. `x = s.indexOf('c', 3);`

23. `}`

24. `System.out.println("x = " + x);`

What is the result?

A. `x = 5`

B. `x = 3`

C. `x = 6`

D. `x = 4`

E. `x = 2`

**Answer: D**

### Question No : 29 - (Topic 1)

Given:

3. `int calc() {`

4. `long x = 40L;`

5. `int i = 30;`

6. `i = x;`

7. `System.out.println("result is: " + i);`

8. `}`

What is the result of calling `calc()`?

A. Compilation fails because of an error at line 6.

B. Compilation fails because of an error at line 4.

C. result is: 40

D. result is: 30

**Answer: A**

### Question No : 30 - (Topic 1)

Which is an appropriate description of session beans?

- A. They are used to store persistent data.
- B. They are used to implement business processes.
- C. They are used to represent data in an RDBMS.
- D. They are used to share data among clients.

**Answer: B**

**Question No : 31 - (Topic 1)**

Which is NOT associated with the web tier in a J2EE web-based application?

- A. JavaMail
- B. HTML
- C. message-driven beans
- D. JNDI
- E. JavaBeans

**Answer: C**

**Question No : 32 - (Topic 1)**

Which two are valid? (Choose two.)

- A. 

```
class EnumTest {
public static void main(String args[]) {
enum Num { ONE, TWO, THREE, FOUR }
System.out.println(Num.ONE);
}
```
- B. 

```
class EnumTest {
enum Days { Sat, Sun, Mon, Tue, Wed, Thu, Fri }
public static void main(String args[]) {
System.out.println(Days.Sat);
}
```
- C. 

```
class EnumTest {
enum Colors { Red = 1, Green = 2, Blue = 4, Yellow = 8 }
public static void main(String args[]) {
System.out.println(Colors.Red);
```

```
}  
D. enum Suit { CLUBS, DIAMONDS, HEARTS, SPADES }  
class EnumTest {  
public static void main(String args[]) {  
System.out.println(Suit.CLUBS);  
}  
}
```

**Answer: B,D**

### Question No : 33 - (Topic 1)

Which two are represented in a UML class diagram? (Choose two.)

- A. relationships between classes and interfaces
- B. ways to test an application
- C. the interactions between objects in sequential order
- D. operations of classes and interfaces

**Answer: A,D**

### Question No : 34 - (Topic 1)

Given:

4. int n1 = 22, n2 = 67, n3 = 0, n4 = 47, n5 = 17, n6 = 50;

5. boolean b = true;

Which three evaluate to true? (Choose three.)

- A.  $!(n1 < n3) \ \&\& \ (n5 \neq n4)$
- B.  $(n3 < n5) \ || \ (n2 \leq n1)$
- C.  $(n2 > n6) \ || \ b$
- D.  $(!b) \ \&\& \ (n1 \leq n4)$
- E.  $(n2 < n6) \ \&\& \ (n4 \geq n1)$

**Answer: A,B,C**

**Question No : 35 - (Topic 1)**

Which option will correctly initialize the property com.example.property to someValue when invoking java?

- A. com.example.property=someValue
- B. -Pproperty:someValue
- C. -P com.example.property someValue
- D. -Pcom.example.property:someValue
- E. -Dcom.example.property=someValue

**Answer: E**

**Question No : 36 - (Topic 1)**

Which is an advantage of applets over HTML/JavaScript clients?

- A. Applets are more widely supported by browsers.
- B. Applets are downloaded more quickly to the client.
- C. Applets can use a wider variety of UI components.
- D. In their default state, applets have access to the client's computer.

**Answer: C**

**Question No : 37 - (Topic 1)**

Which two keywords directly support looping? (Choose two.)

- A. foreach
- B. switch
- C. while
- D. if
- E. for

**Answer: C,E**

**Question No : 38 - (Topic 1)**

Why should package names in Java be unique?

- A. to programatically declare specific ownership of classes in the package
- B. to allow classes in the package to be accessed by classes outside of that package
- C. to provide the Internet location from which the package can be downloaded
- D. to avoid class name conflicts if two development groups use the same package and class names

**Answer: D**

**Question No : 39 - (Topic 1)**

Which two are associated with the business tier in a J2EE web-based application? (Choose two.)

- A. stateless session beans
- B. servlets
- C. JSP
- D. HTML
- E. entity beans

**Answer: A,E**

**Question No : 40 - (Topic 1)**

Which two are true about HTML? (Choose two.)

- A. It is used by the browser to display the client user interface.
- B. It contains APIs that are used to access data in an RDBMS.
- C. It is an object-oriented programming language.
- D. It can be generated dynamically by servlets.

**Answer: A,D**

**Question No : 41 - (Topic 1)**

Which three classes are part of the java.io package? (Choose three.)

- A. File
- B. Socket
- C. URL
- D. Reader
- E. String
- F. BufferedWriter

**Answer: A,D,F**

**Question No : 42 - (Topic 1)**

Which two are advantages of using J2EE server-side technologies in a web-based application? (Choose two.)

- A. complexity
- B. network latency
- C. monolithic design
- D. scalability
- E. separation of concerns

**Answer: D,E**

**Question No : 43 - (Topic 1)**

Which two technologies are primarily focused on developing Web Services? (Choose two.)

- A. UDDI
- B. JSP
- C. RDBMS
- D. WSDL
- E. JDBC

**Answer: A,D**

**Question No : 44 - (Topic 1)**

Given:

```
1. public class Boat{
2. // insert code here
3. public void setGas(int v){
4. gas = v;
5. }
6. }
```

Which, inserted at line 2, is valid and demonstrates encapsulation?

- A. protected int gas;
- B. private int gas;
- C. public int gas;
- D. struct int gas;

**Answer: B**

### Question No : 45 - (Topic 1)

Which two describe benefits of encapsulation? (Choose two.)

- A. Code is more useful because attributes of the class can be accessed by other classes for both reading and writing.
- B. Code is more efficient because attributes of the class can be accessed directly by other classes, without the overhead of going through access methods.
- C. Code is more reusable because the attributes of the class are protected from direct modification by other code.
- D. Code is more flexible because the attributes can be modified directly from code in other packages.
- E. Code is safer because attributes of the class CANNOT be directly modified by code outside the class.

**Answer: C,E**

### Question No : 46 - (Topic 1)

Which two are true about J2ME? (Choose two.)

- A. It provides a built-in database.
- B. It is the foundation platform for J2SE.
- C. It can be used to create applications that run on mobile phones.
- D. It can be used to create Swing applications.

**Answer: A,C**

**Question No : 47 - (Topic 1)**

Which package contains the classes used to create a socket?

- A. javax.swing
- B. java.io
- C. java.util
- D. java.net
- E. java.awt
- F. java.lang

**Answer: D**

**Question No : 48 - (Topic 1)**

Given:

- 3. int num = 0, count;
- 4. while ( num < 3 ) {
- 5. num++;
- 6. // insert code here
- 7. System.out.println("num = " + num + " : count = " + count);
- 8. }
- 9. }

Which, inserted at line 6, produces the following output?



num = 1 : count = 1

num = 1 : count = 2

num = 2 : count = 1

num = 2 : count = 2

num = 3 : count = 1

num = 3 : count = 2

- A. while ( ++count < 3 ) {
- B. for ( count = 1 ; count < 3 ; count++ ) {
- C. for ( count = 0 ; count < 3 ; count++ ) {
- D. while ( ++count < 2 ) {
- E. for ( count = 1 ; count < 2 ; count++ ) {

**Answer: B**

### Question No : 49 - (Topic 1)

Given:

1. class Test2 {
2. static String setMessage(String str) {
3. return str + "How are you doing?";
4. }
- 5.
6. public static void main(String[] args) {
7. String str = "Hello! ";
8. str = setMessage(str);
9. System.out.println("str : " + str);
10. }
11. }

What is the result?

- A. str : Hello! How are you doing?
- B. Compilation fails because of an error at line 7.
- C. Compilation fails because of an error at line 8.
- D. Compilation fails because of an error at line 2.
- E. Compilation fails because of an error at line 3.
- F. str : Hello!
- G. str : How are you doing?

Answer: A

**Question No : 50 - (Topic 1)**

Click the Exhibit button.

Which is true?

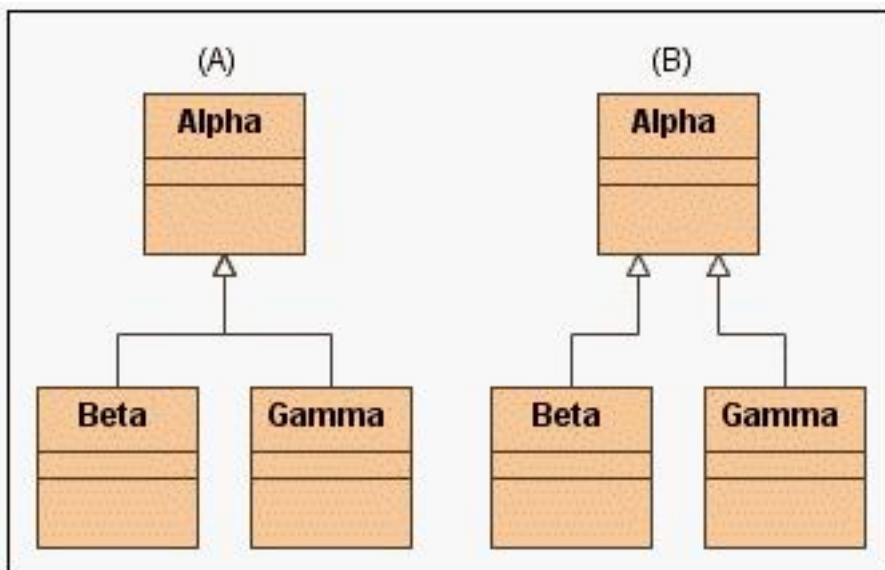

- A. Diagrams A and B are both valid, but have different meanings.
- B. Both diagrams are invalid.
- C. Diagrams A and B are equivalent.
- D. Only diagram A is valid.
- E. Only diagram B is valid.

Answer: C

**Question No : 51 - (Topic 1)**

Which three are responsibilities of the business tier in a multitier web-based application with web, business, and EIS tiers? (Choose three.)

- A. to integrate with legacy applications
- B. to provide business logic
- C. to generate dynamic content
- D. to participate in transactions
- E. to process requests from web-based clients

**Answer: A,B,D**

**Question No : 52 - (Topic 1)**

Given:

1. // insert code here
2. void play();
3. void stop();
4. }
5. // insert code here
6. public void play() { }
7. public void stop() { }
8. }

Which, inserted at lines 1 and 5, allows the code to compile?

- A. 1. interface Player {  
5. class DVDPlayer implements Player {
- B. 1. implements Player {  
5. class DVDPlayer interface Player {
- C. 1. abstract class Player {  
5. class DVDPlayer extends Player {

- D. 1. interface Player {
- 5. class DVDPlayer extends Player {
- E. 1. class Player {
- 5. interface DVDPlayer implements Player {

**Answer: A**

**Question No : 53 - (Topic 1)**

Which type of primitive can be assigned a new value within a conditional expression?

- A. char
- B. boolean
- C. byte
- D. int
- E. short

**Answer: B**

**Question No : 54 - (Topic 1)**

Given:

- 1. class Test {
- 2. public static void main(String args[]) {
- 3. String str = new String("Welcome");
- 4. // insert code here
- 5. }
- 6. }

Which, inserted at line 4, produces the output true?

- A. System.out.println(str.trim());
- B. System.out.println(str.startsWith("W"));
- C. System.out.println(str.indexOf("W"));
- D. System.out.println(str.startsWith('W'));

E. System.out.println(str.indexOf(1));

**Answer: B**

**Question No : 55 - (Topic 1)**

Which is NOT a correct statement about entity beans?

- A. They are persisted using BMP and CMP.
- B. They are used to share data among clients.
- C. They are used to store persistent data.
- D. They are used to implement business processes.
- E. They are used to represent data stored in an RDBMS.

**Answer: D**

**Question No : 56 - (Topic 1)**

Which is valid?

- A. package com.example;  
class Test { }  
import java.util.\*;
- B. package com.example;  
import java.util;  
import java.\*;  
class Test { }
- C. package com.example;  
import java.util.\*;  
import java.io.\*;  
class Test { }
- D. import java.util.\*;  
package com.example;  
class Test { }
- E. package com.example;  
package com.sun;  
import java.util.\*;  
class Test { }

**Answer: C**

**Question No : 57 - (Topic 1)**

Which two are true? (Choose two.)

- A. HTML can be used only for displaying images.
- B. XML is an extension of HTML.
- C. HTML is an acronym for HyperText Markup Language.
- D. HTML is the language used to publish web pages on the World Wide Web.

**Answer: C,D**

**Question No : 58 - (Topic 1)**

What is the definition of the acronym SQL?

- A. Special Queue Language
- B. Structured Query Language
- C. Special Query Language
- D. Structured Queue Language
- E. System Query Language
- F. System Queue Language

**Answer: B**

**Question No : 59 - (Topic 1)**

Which is true?

- A. The JDBC API is included in J2SE.
- B. JDBC is used to connect to MOM (Message-Oriented Middleware) products.
- C. All JDBC drivers are pure Java.
- D. The JDBC API is an extension of the ODBC API.

**Answer: A**

**Question No : 60 - (Topic 1)**

Given that TestClass relies on classes in the someJar.jar file in /some/dir, which javac invocation will correctly compile TestClass in the current directory?

- A. javac -classpath /some/dir/someJar.jar ./TestClass
- B. javac -classpath /some/dir/someJar.jar ./TestClass.java
- C. javac -classpath /some/dir/\* .jar \*.java
- D. javac /\*.java
- E. javac -classpath someJar.jar -sourcepath . TestClass.java

**Answer: B**

**Question No : 61 - (Topic 1)**

Given:

```
interface Writable { }
```

```
interface Erasable { }
```

Which three are valid? (Choose three.)

- A. public class Pencil implements Erasable,Writable { /\*...\*/ }
- B. public interface Pencil extends Writable { /\*...\*/ }
- C. public interface Pencil implements Writable { /\*...\*/ }
- D. public class Pencil implements Writable { /\*...\*/ }
- E. public class Pencil extends Writable { /\*...\*/ }

**Answer: A,B,D**

**Question No : 62 - (Topic 1)**

A Java programmer wants to develop a small application to run on mobile phones. Which Java edition (or editions) are required to develop the application?

- A. only J2ME
- B. J2SE and J2EE
- C. only J2EE
- D. J2SE and J2ME
- E. only J2SE
- F. J2EE and J2ME

**Answer: D**

**Question No : 63 - (Topic 1)**

Which Java technology provides a standard API for relational database access?

- A. JDC
- B. JMS
- C. JSP
- D. JNDI
- E. JDBC

**Answer: E**

**Question No : 64 - (Topic 1)**

Which is true?

- A. You must use JDBC to connect an RDBMS to a Java application.
- B. JDBC is designed to provide a bridge between servlets and EJB technology.
- C. Classes in the JDBC API include implementations of JDBC drivers.
- D. The JDBC API is located within the java.sql and javax.sql packages.

**Answer: D**

**Question No : 65 - (Topic 1)**

Which package contains classes to read from, and write to, files?

- A. java.net



- B. javax.swing
- C. javax.file
- D. java.util
- E. java.io
- F. java.lang
- G. java.stream

**Answer: E**

**Question No : 66 - (Topic 1)**

Which two are characteristics of applets? (Choose two.)

- A. Because it executes on the web server, the client does NOT incur the processing overhead.
- B. Applet security is provided by Java's sandbox security model.
- C. Applets can be developed quickly using HTML/JavaScript tags.
- D. Because code is downloaded at the time of execution, applets are easy to distribute.

**Answer: B,D**

**Question No : 67 - (Topic 1)**

Which two are benefits of servlets? (Choose two.)

- A. They allow you to embed Java code in HTML files.
- B. They represent data in a persistent store.
- C. They can produce dynamic content in response to web client requests.
- D. Their lifecycles are managed by the container.

**Answer: C,D**

**Question No : 68 - (Topic 1)**

Which four are legal declarations? (Choose four.)

- A. String st = null;

- B. String st = "Hello";
- C. String st == 'Hello';
- D. String st = 'Hello';
- E. String st == "Hello";
- F. String[] st = new String[1];
- G. String st = new String("Hello");

**Answer: A,B,F,G**

**Question No : 69 - (Topic 1)**

Given:

1. class Test {
2. public static void main(String args[]) {
3. int i = 1;
4. while (i-- > 1) {
5. System.out.println("i : " + i);
6. }
7. }
8. }

What is the result?

- A. i : 1
- B. i : -1
- C. i : 0
- D. No output is produced.
- E. Compilation fails.

**Answer: D**

**Question No : 70 - (Topic 1)**

What keyword is used to create an enumeration?

- A. ENUM
- B. const
- C. enumeration
- D. There is no keyword for creating enumerations. The Enum class must be used instead.
- E. enum

Answer: E

**Question No : 71 - (Topic 1)**

Click the Exhibit button. Which correctly implements the relationship shown in the diagram?

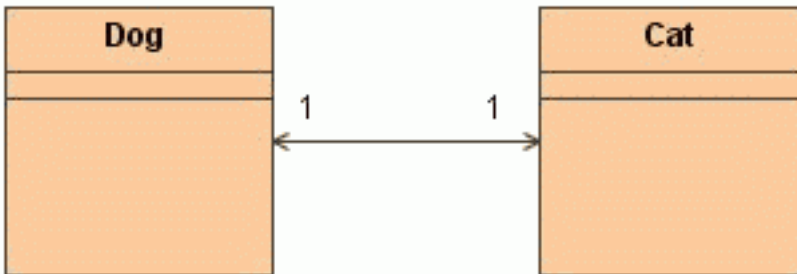

- A. 

```
class Cat {
Dog d;
}
class Dog { }
```
- B. 

```
class Cat { }
class Dog {
Cat c;
}
```
- C. 

```
class Cat { }
class Dog { }
```
- D. 

```
class Cat {
Dog d;
}
class Dog {
Cat c;
}
```

Answer: D

**Question No : 72 - (Topic 1)**

Which Java technology provides a unified interface to multiple naming and directory services?

- A. JNI
- B. EJB
- C. JDBC
- D. JNDI
- E. JavaMail

**Answer: D**

**Question No : 73 - (Topic 1)**

Given:

```
1. class Book {  
2. public String title;  
3.  
4. public void setTitle(String title) {  
5. if (checkTitle(title)) this.title = title;  
6. }  
7. public String getTitle() {  
8. return title;  
9. }  
10. private boolean checkTitle(String newTitle) {  
11. // code that verifies proposed title change  
12. }  
13. }
```

Which two are true? (Choose two.)

- A. The title attribute is protected from direct modification by outside code.

- B. The Book class demonstrates encapsulation.
- C. The Book class does NOT provide information hiding.
- D. The Book class adheres to the JavaBeans naming conventions.
- E. The checkTitle method can be accessed from outside the Book class.

**Answer: C,D**

**Question No : 74 - (Topic 1)**

Which is true about MIDlets?

- A. MIDlet devices are not required to allow applications to be uninstalled.
- B. The only API used to create MIDlets is the MIDP API.
- C. Devices that support MIDlets must allow the MIDlets to access the device's low-level functions.
- D. Devices that run MIDlets must provide software that manages wireless downloading of applications.

**Answer: D**

**Question No : 75 - (Topic 1)**

Which two are characteristics of an RDBMS? (Choose two.)

- A. An RDBMS represents data using three-dimensional tables.
- B. J2EE provides a cross-platform RDBMS.
- C. Java technologies provide capabilities for connecting a legacy RDBMS to a web application.
- D. Business-tier applications use session beans to represent rows in an RDBMS.
- E. An RDBMS represents data using two-dimensional tables.

**Answer: C,E**

**Question No : 76 - (Topic 1)**

You are asked to create code that defines a Beverage, and includes method implementation code for some beverage behaviors. Beverage subtypes will be required to provide implementations of some, but not all, of the methods defined in Beverage.

Which approach correctly implements these goals?

- A. Create an abstract Beverage class that defines only abstract methods.
- B. Create a Beverage interface that all beverage subtypes must implement.
- C. Create an abstract Beverage class that defines both abstract and concrete methods.
- D. Create a concrete Beverage class that defines both abstract and concrete methods.

**Answer: C**

**Question No : 77 - (Topic 1)**

Which two are NOT Enterprise Beans? (Choose two.)

- A. JavaBeans
- B. message-driven beans
- C. session beans
- D. entity beans
- E. business beans

**Answer: A,E**

**Question No : 78 - (Topic 1)**

Which two are true? (Choose two.)

- A. An interface can implement another interface.
- B. A class can implement more than one interface.
- C. Many classes can implement the same interface.
- D. Every class must implement at least one interface.

**Answer: B,C**

**Question No : 79 - (Topic 1)**

Which two are associated with the business tier in a J2EE web-based application? (Choose two.)